

Power Flow analysis by Unified Power Flow Controller

Poonam Chand Sahu, Neelesh Kumar Patel

Disha Institute of Management and Technology, Raipur, Chhattisgarh, India

Abstract— It is very important to control the power flow along the transmission line. Thus to control and improve the performance of ac power systems, we need the various different types compensators. Now-a-days the Flexible AC Transmission Systems (FACTS) is very popular and essential device in power systems. After introducing the FACTS technology, power flow along the transmission lines becomes more flexible and controllable. Several FACTS-devices have been introduced for various applications in power system. Among a variety of FACTS controllers, Unified Power Flow Controller (UPFC) is the most powerful and versatile device.

Keywords— FACTS, UPFC, reactive power, active power.

I. INTRODUCTION

Flexible AC Transmission System (FACTS): Alternating current transmission systems incorporating power electronic-based and other static controllers to enhance controllability and increase power transfer capability. The main objective of using static var compensator with supplementary controller is to improve the power factor in distribution system during normal as well as abnormal condition and also to improve the voltage stability of system during fault condition so that to meet continuity of supply. The ultimate objective of compensation is to increase transmittable power. This may require to improve the KW capacity of transformer and alternators, to improve the regulation of line and to decrease overall cost per units. [3]

II. STATIC VAR COMPENSATOR

The UPFC is a device which can control simultaneously all three parameters of line power flow (line impedance, voltage and phase angle). It is one of the FACTS family that used to optimum power flow in transmission. The UPFC is a combination of static synchronous compensator (STATCOM) and static synchronous compensator (SSSC). Both converters are operated from a common dc link with a dc storage capacitor. The real power can freely flow in either direction between the two-ac branches. Each converter can independently generate or absorb reactive power at the ac output terminals[11]. The controller provides the

gating signals to the converter valves to provide the desired series voltages and simultaneously drawing the necessary shunt currents. In order to provide the required series injected voltage, the inverter requires a dc source with regenerative capabilities. The possible solution is to use the shunt inverter to support the dc bus voltage[30]. The UPFC can perform the function of STATCOM and SSSC and phase angle regulator. Besides that the UPFC also provides an additional flexibility by combining some of the function above. UPFC has also a unique capability to control real and reactive power flow simultaneously on a transmission system as well as to regulate the voltage at the bus where it's connected. The UPFC can also increase the capability of the power flow to the load demand until it reaches its limit in the short period. At the same time the UPFC also can increase the security system by increasing the limit of transient stability, fault and the over load demand. Lastly the UPFC also can reduce the value of the reactive power and will optimum the real power flow through the transmission line[20]. The Unified Power Flow Controller (UPFC) was proposed first time for real time turn-off time control and dynamic compensation of ac transmission systems.

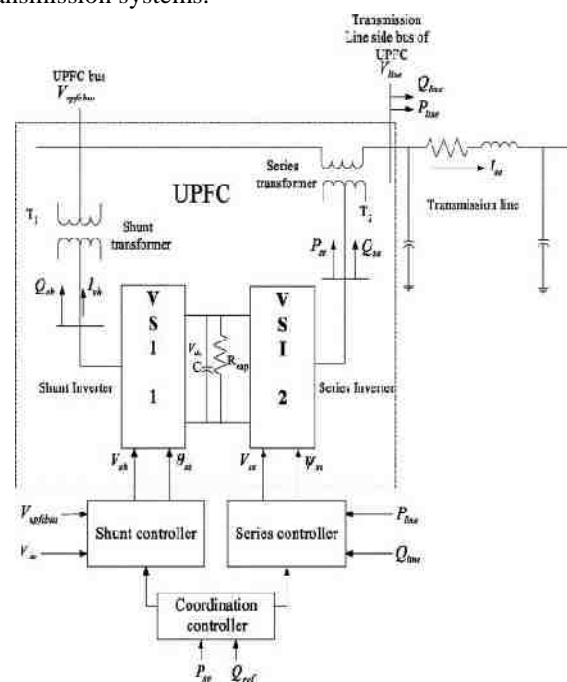

Fig.1.1: The Schematic Transmission System of UPFC

Fig.1.1 shows the Unified Power Flow Controller consists of two switching converters [18][25]. Which are considered as voltage sourced inverters using gate thyristor valves, as illustrated in. These inverters, labeled "VSC1" and "VSC2" in the figure are operated with a common dc link provided by a dc storage capacitor. With this arrangement the ac power converter in which the real power can freely flow in either direction between the ac terminals of the two inverters and each inverter can independently generate as well as absorb the reactive power at its own ac output terminal. Since the series converter of the UPFC can inject a voltage with variable magnitude and phase angle it can exchange real power with the transmission line with the help of series transformer. However a UPFC as a whole (both converter) cannot supply or absorb real power in steady state (except for the power drawn to compensate for the losses). Unless it has a power source at DC terminals. Thus the shunt branch is required for compensate (from the system for any real power drawn/supplied by the series branch and the losses. when the power balance is not maintained, at that situation the capacitor cannot remain at a constant voltage. Shunt branch also can independently exchange reactive power with the system[31]. The Unified Power Flow Controller from the stand point of conventional power transmission based on reactive series compensation, shunt compensation, and phase shifting, the UPFC is the only device which can fulfill all these functions and thereby meet multiple control objectives by adding the injected voltage V_{pq} , with appropriate amplitude and phase angle, to the terminal voltage V_0 Using phasor representation, the basic UPFC power flow control functions are illustrated in Fig. 1.2 [20].

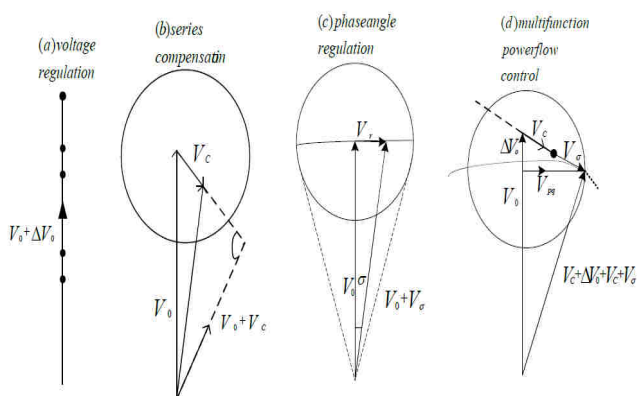

Fig.1.2 Basic UPFC control function. (a) Voltage Regulation (b) Series compensation (c) Angle regulation (d) Multi-function power flow controller

Fig.1.2 is shown terminal voltage regulation, similar to that obtainable with a transformer tap-changer having infinitely small steps[18][34]. It is shown at (a) where $V_m = \Delta V$ (boldface letters represent phasors) is injected in-phase (or anti-phase) with V_0 . Series capacitive compensation is shown at (b) where $V_m = V_c$ is injected in quadrature with the line current I . Transmission angle regulation (Phase shifting) is shown at (c) where $V_{pq} = V_\sigma$ is injected with an angular relationship with respect to V_0 that achieves the desired σ phase shift (advance or retard) without any change in magnitude[20].

$$V_{pq} = \Delta V + V_c + V_\sigma$$

The shunt converter draws a controlled current from the system. One component of this current is I_p which is automatically determined by the requirement to balance the real power supplied to the series converter through the DC link. This power balance is enforced by regulating the DC capacitor voltage by feedback control[17]. The other component of the shunt converter current is the reactive current, I_r which can be controlled in a similar fashion as in a STATCOM. There are two operating (control) modes for a STATCOM or the shunt converter. These are, VAR control mode where the reactive current reference is determined by the inductive or capacitive VAR command. The feedback signals are obtained from current transformers (CT) typically located on the bushings of the coupling (step down) transformer[17][30]. Automatic voltage control mode where the reactive current reference is determined by the output of the feedback voltage controller which incorporates a droop characteristic (as in the case of a SVC or a STATCOM). The voltage feedback signals are obtained from potential transformers (PT) measuring the voltage V_1 at the substation feeding the coupling transformer [17].

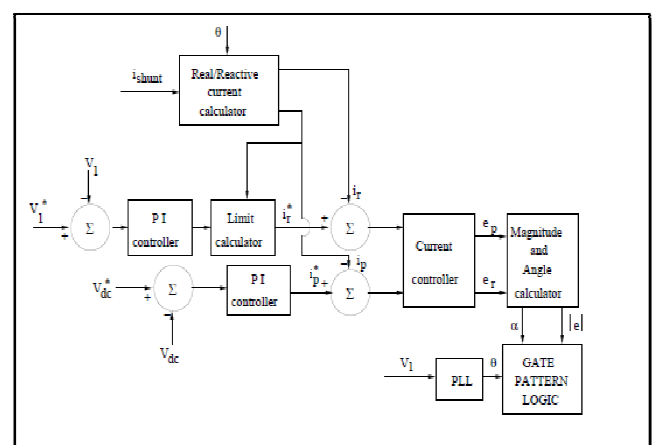

Fig.1.3: Block diagram of shunt VSC controller
III. ACTIVE AND REACTIVE POWER CONTROL BY UPFC

In figure (4.14) a simple two machine (or two bus ac inertia) system with sending-end voltage V_s , receiving-

end voltage V_r , and line (or tie) impedance X (assumed, for simplicity, inductive) is shown. At (b) the voltages of the system in form of a phasor diagram are shown with transmission angle δ and $V_s = V_r = V$. At the receiving ends of the line the transmitted active and reactive power are $P = V^2/X \sin\delta$ and $Q = Q_s = Q_r = V^2/X (1 - \cos\delta)$ [20].

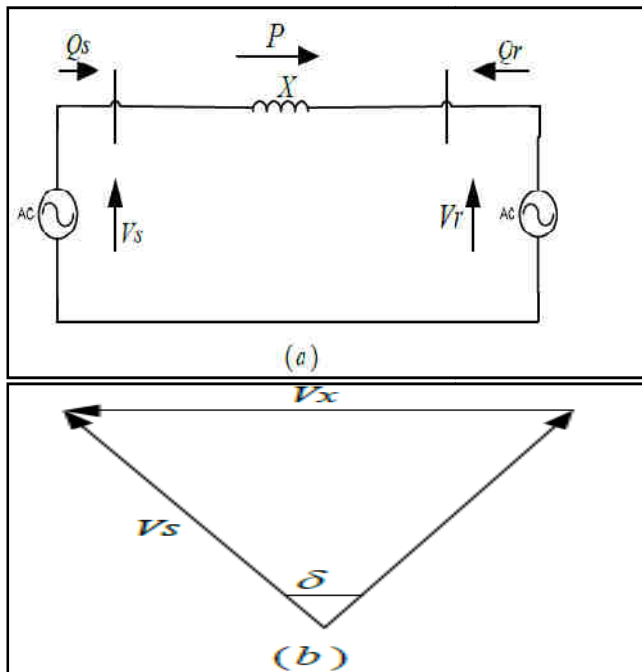

Fig.1.4: (a) Simple two machine system (b) Related voltage phasors

Fig.1.4(a) and (b) are show the basic power system of with the known transmission characteristics is introduced to providing a vehicle to establish the capability of the UPFC to control the transmitted real power P and the reactive power demands, Q_s , and Q_r , at the sending-end and, respectively, the receiving-end of the line[17][18].

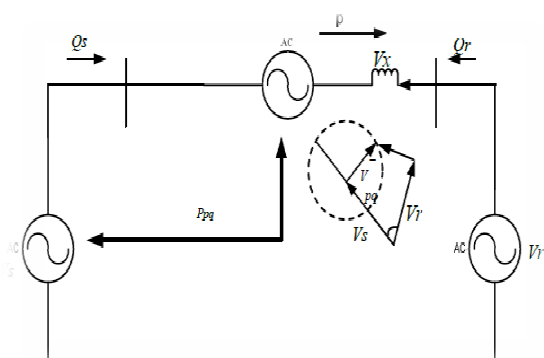

Fig.1.5: Two-machine system with the Unified Power Flow Controller

Fig.1.5 are show two-machine system with the Unified Power Flow Controller[1][37]. Consider Fig.1.5 where the simple power system of Fig.1.4 is expanded to include the UPFC. In the previous section explained that the UPFC is represented by a controllable voltage source in

series with the line which, can generate or absorb reactive power that it negotiates with the line, but the real power it exchanges must be supplied to it, or absorbed from it, by the sending-end generator. The voltage which is injected by the UPFC in series with the line is represented by phasor V_{pq} ($0 \leq V_{pq} \leq 0.5$ p. u) and angle ρ ($0 \leq \rho \leq 360^\circ$) measured from the given phase position of phasor as illustrated in the figure. The line current is represented by phasor I , flows through the series voltage source, V_{pq} and generally results in both reactive and real power exchange

IV. MATLAB SIMULATION

The model of UPFC. Voltage source is connected to transmission line. In transmission has connected to three phase transformer. It other side is also connected three transformer in series connection. It has two inverter are connected, they are STATCOM and SSSC. Where STATCOM is control active power and reactive power and SSSC is control the voltage magnitude and phase angle. In UPFC controlling is done by the both VSC devices, state and is control by SSSC. It use gate pulse generator circuit because controlling of gate pulse generator circuit is easy. In gate pulse generator circuit input voltage and firing angle where compared and then send its output to gate pulse Thyristor. It series shunt type of FACTS devices. It easy to control as compare to capacitor and other active device. STATCOM is only control to active and reactive power and SSSC is only control to voltage magnitude and phase angle between voltage and current. So we use UPFC because it is a combination of both STATCOM and SSSC.

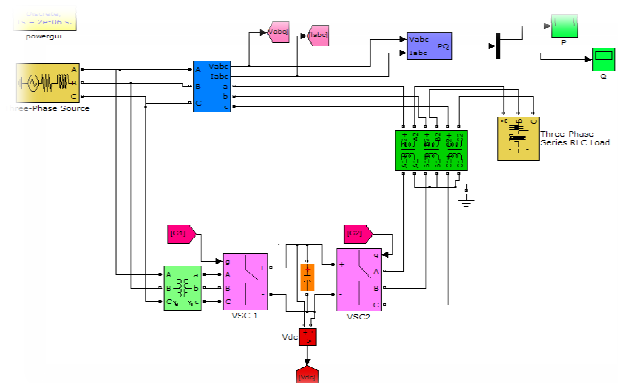

Fig.1.6:UPFC simulation modal

V. RESULTS AND DISCUSSION

In this simulation model both active and reactive power are analyzed. In domestic and industries large inductive loads are used which consumes heavy reactive power. So there is a essential requirement of reactive power compensation. Reactive power can be compensated using

FACTS devices but controlling of these devices are complex, while UPFC is easy to control.

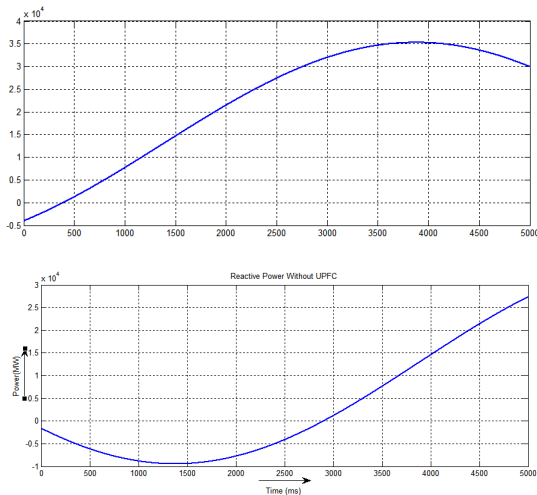

Fig.1.7: Active and Reactive Power without UPFC

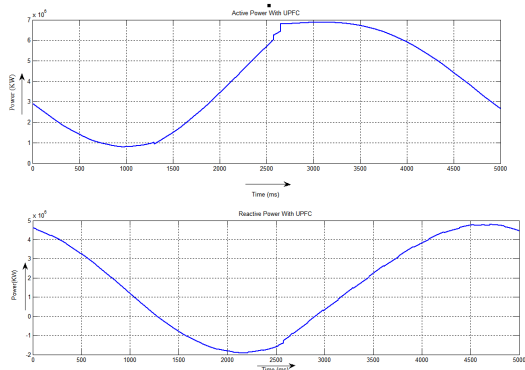

Fig.1.8: Active and Reactive Power with UPFC

REFERENCES

- [1] G.Hingorani and L.Gyugyi "Understanding FACTS: Concepts and Technology of Flexible AC Transmission Systems", IEEE,1999.
- [2] Keri, A.J.F Mehraban, A.S ; Lombard, X. ;Eiriachy, A. "Unified power flow controller (UPFC): modeling and analysis", IEEE,1999
- [3] B.Gopinath, S.Suresh Kumar, Juvan Michael "Unified Power Flow Controller (UPFC) for Dynamic Stability in Power System using Modern Control Technique" IJEAT, 2014.
- [4] Md. Habibur Rahman , Md. Harun-Or-Rashid, Sohel Hossain "Stability Improvement of Power System By Using PSC Controlled UPFC", IJSETR, 2013.
- [5] Vaibhav S Kale, Prashant R Patil, Ravi Khatri "Unified Power Flow Controller for POWER SYSTEMImprovement", IJESE, 2010.
- [6] P.Pavan Kumar N.Poornachandrarao "Improvement of power flow in the power system network by using UPFC device", IJERA, 2012.
- [7] B.Gopinath, Dr.S.Suresh Kumar, S.Mohanapriya "An Intelligent Technique For Unified Power Flow Controller With Matrix Converter", IJSRP, 2013.

- [8] B. Vijay Kumar a, N.V. Srikanth "Optimal location and sizing of Unified Power Flow Controller (UPFC) to improve dynamic stability: A hybrid technique", IJAREEIE, 2014.
- [9] Arindam Ghosh, Gerard Ledwich, "Power Quality Enhancement Using Custom Power Devices", 2002.